



**LIGHT STAND
(5600 series)
04-0196**

**Installation/Repair
Information**

INSTALLATION:

- 1) Rotate the lower Light Stand so the light switch is orientated in the desired direction.
- 2) Attach the lower Light Stand to the upper using the 3/8-16 x 1-1/4 bolts (Item 3) and hardware (Items 11 & 15).
- 3) Run the light's power cord on the upper Light Stand to the outlet on the lower Light Stand and secure it using the clamp (Item 10) and screw (Item 4).
- 4) **(At least two people are required for this next step.)** Lift the Light Stand assembly into place onto the top of the Tire Spreader column and tray. Use the two 3/8-16 x 1 bolts (Item 2) and washers (Items 15) at the front of the Tire Spreader and the 3/8-16 x 1-1/4 bolts (Item 3) and hardware (Items 11 & 15) at the back to fasten the light assembly to the spreader.
- 5) Plug the power cord from switch to either the outlet located on the side of the spreader column, or to the nearest 110/120V outlet where the cord won't be a tripping hazard.

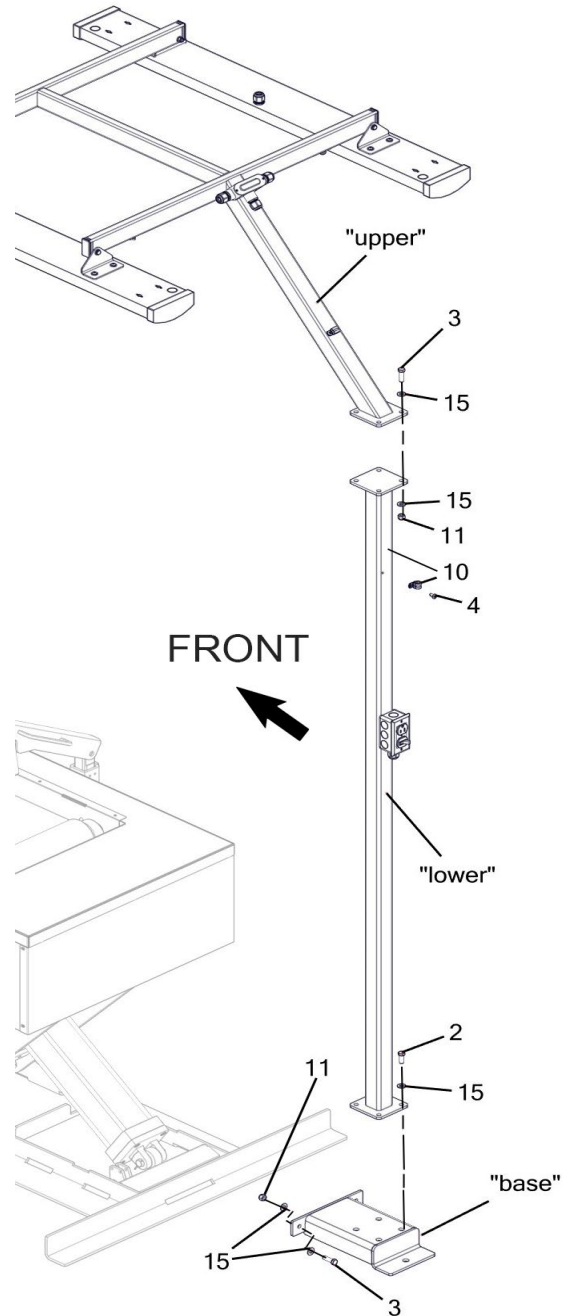

REPAIR PARTS

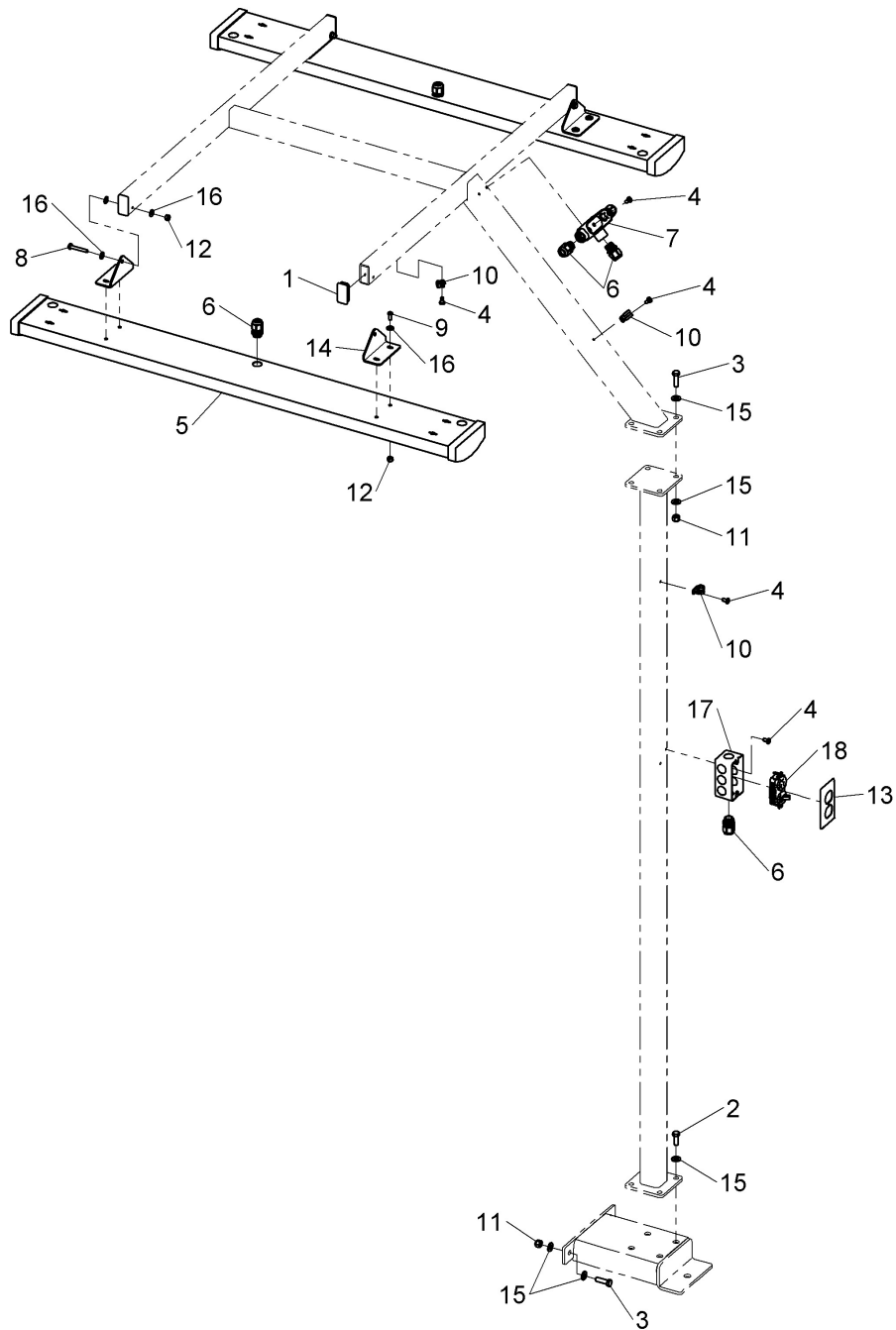

ITEM	PART NO.	DESCRIPTION	ITEM	PART NO.	DESCRIPTION
1	11-0137	CAPLUG	10	53-0036	LOOP CLAMP
2	028-021	3/8-16 X 1 SCREW	11	055-154	3/8-16 LOCK NUT
3	028-046	3/8-16 X 1-1/4 SCREW	12	055-160	1/4-20 LOCK NUT
4	028-148	1/4-20 X 1/2 SCREW	13	58-0008	DUPLEX RECEPTICLE COVER
5	40-0120	LED LIGHT FIXTURE	14	72-0649	LIGHT BRACKET
6	43-0070	CABLE GRIP	15	108-015	3/8 WASHER
7	43-0093	CONDUIT TEE	16	108-110	1/4 WASHER
8	50-0088	1/4-20 X 1-3/4 SCREW	17	980-001	ELECTRICAL BOX
9	50-0125	1/4-20 X 5/8 SCREW	18	980-005	COMBO SWITCH / RECEPTICAL