



MODEL
HD-BTC

Installation, Operation
& Repair Parts
Information

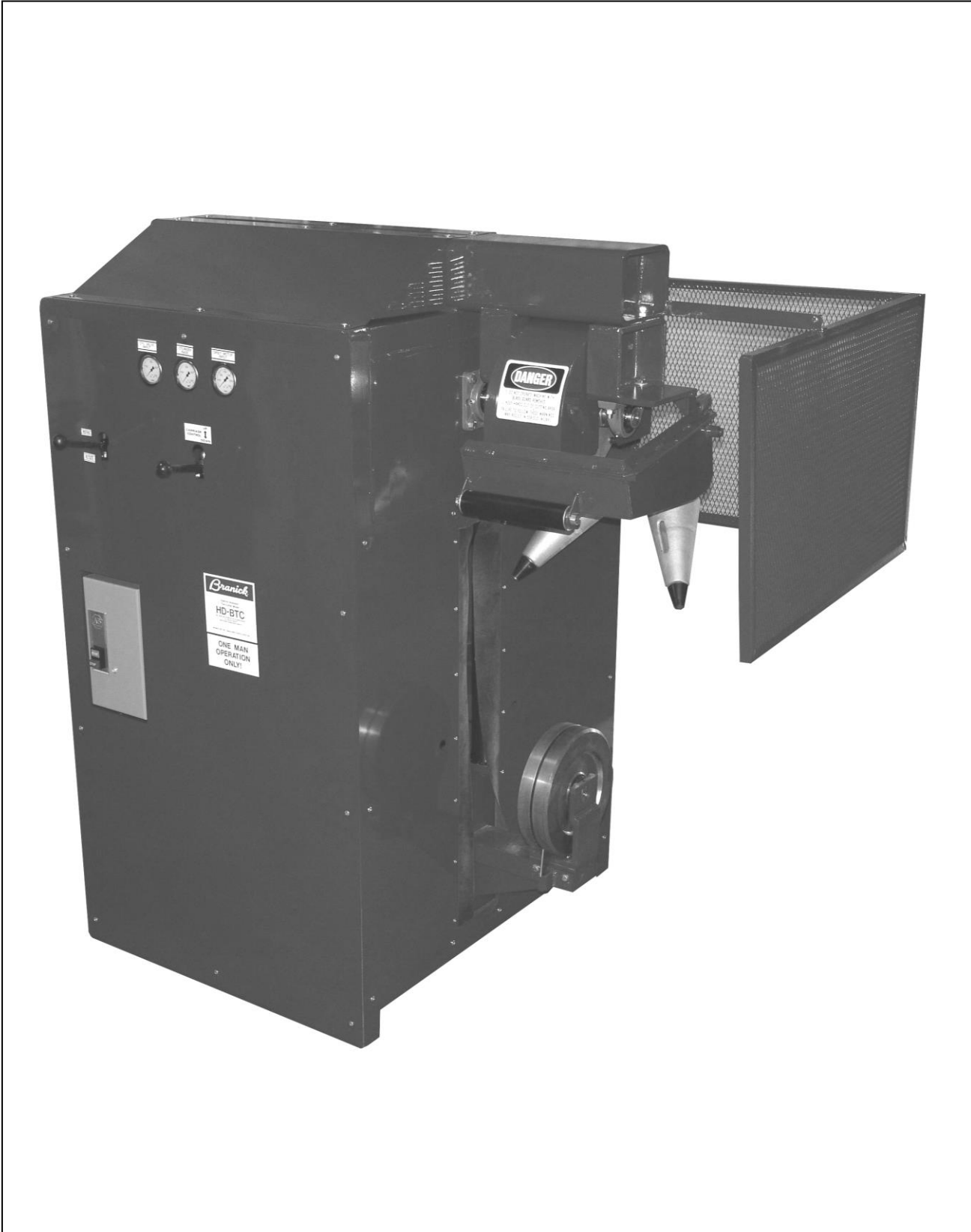

TABLE OF CONTENTS

SAFETY INSTRUCTIONS	1
DEFINITIONS	1
SPECIFICATIONS	2
INSTALLATION INSTRUCTIONS	2
OPERATING INSTRUCTIONS	2
MAINTENANCE	3
REPAIR PARTS	4
WARRANTY	11

SAFETY INSTRUCTIONS

- NEVER allow unauthorized personnel to operate this product.
- NEVER use this product for anything other than its intended use.
- THOROUGHLY train new employees in the proper use and care of this product.
- PROHIBIT unauthorized personnel from being in shop area while this product is in use.

DEFINITIONS

- **CAUTION:** Indicates a potentially hazardous situation, which if not avoided, may result in damage to property or minor personal injury.
- **HAZARD:** A source of potential injury to a person.
- **MAINTENANCE:** Those actions that preserve the correct and proper conditions under which the machine shall be used. This may include adjustment, replacement of wear items, lubrication and cleaning, but not modifications or repair of damage.
- **MAY:** This word is understood to be permissive.
- **MUST:** This word is understood to be mandatory.
- **OPERATION:** The correct and proper use of the machine as described in this manual.
- **SAFETY ALERT SYMBOL:** A symbol that indicates a potential personal safety hazard. It is composed of an equilateral triangle surrounding an exclamation point.
- **SHALL:** This word is understood to be mandatory.
- **SHOULD:** This word is understood to be advisory.
- **WARNING:** Indicates a potentially hazardous situation, which if not avoided, may result in death or serious personal injury.

CAUTION

During the initial set-up you will be asked to perform several tests with the front panel and some of the left side panels off. Read and obey all safety warnings before removing or opening these panels. Keep hands out of the cage area and interior of the machine when the power unit is running.

SPECIFICATIONS

Max. Tire Cross Section	19 in (48.26 cm)
Max. Tire Tread Width	16 in (40.64 cm)
Max. Tire Outside Diameter	50 in (127 cm)
Weight	2400 lbs (1089 Kg)
Electrical	230 V / 60 H / 3 Ph

INSTALLATION INSTRUCTIONS

1. Unpack and remove the unit from the shipping carton / pallet.
2. Inspect the unit for any visible damage.
3. Remove the front cover panel.
4. Connect the electrical service to the junction box on the rear of the machine.
5. Start the electric motor by depressing the “Start” button on the front of the machine.
6. Check to ensure the motor is rotating in the same direction as the arrow shown on the motor (checked through left side panel). Pump damage will occur if the motor runs in the wrong direction for a prolonged period of time.
7. Using the lift handle, raise and lower the tire mandrel arm several times to ensure that it moves up and down properly.
8. Depress and release the rotate handle several times to ensure that the blade starts and stops properly.
9. Stop the motor by depressing the “Stop” button of the front of the machine.

OPERATING INSTRUCTIONS

1. Depress the “Start” button on the front of the machine.
2. Raise or lower the mandrel arm so the tire to be cut fits over the mandrel.
3. Raise the mandrel arm until the tire is slightly off the floor. Continue holding the lift handle in a raised position.
4. Depress the rotate handle to start cutter blade. Continue holding the rotate handle while raising the tire mandrel arm until the blade is just through the casing.

NOTE: A light pressure between the side plates and the tire will usually guarantee tire rotation but in most cases the blade side plates do not need to contact the tire to maintain rotation.

5. Release the lift handle for the rest of the cutting process.

CAUTION: DO NOT HOLD THE LIFT HANDLE IN THE UP POSITION DURING THE CUTTING OPERATION. THIS WILL GENERATE EXTRA HEAT CAUSING OIL BREAK-DOWN AND PREMATURE WEAR OF THE COMPONENTS.

6. After cutting is complete, release the rotate handle, lower the tire mandrel arm and remove the casing halves.
7. When all tires have been cut lower the tire mandrel arm and depress the "Stop" button.

MAINTENANCE

- 1) Change the oil filter in the hydraulic system after the first two weeks of operation and again every six months. There is a ball valve located under the left corner of the reservoir to aid in draining the oil (when the handle is down the oil is off). The reservoir was filled with MOBIL DTE24 oil at the factory and should be replaced / refilled with the same.
If the pump, hydraulic motor, rotate valve, orbit valve, or hydraulic cylinder are replaced change the filter at that time and then again after two weeks of operation. There is a large ball valve located between the reservoir and the pump to help you with this. The handle on this valve should be hanging down during normal operation. When replacing a hydraulic component, shut off the large supply valve and remove the hose from the component to the filter manifold otherwise you will siphon oil back through the filter.
- 2) Grease the pillow block bearings, the flanged bearing, the bearings on the mandrel wheel, and the carriage as necessary as part of your daily maintenance. The carriage can be greased through the two one inch holes on the right side of the cutter near the horizontal center of the machine just on either side of the rubber curtain.
- 3) Blade sharpening can be done right on the machine with a file. The blade should be rotating and care taken when sharpening the blade.
- 4) Blade Replacement
 - a. Loosen the set screws in the outer pillow block bearing. Remove the outer pillow block arm by removing the two cap screws on the top of the pillow block support and sliding it off the blade shaft. The shield right side and pivoting shield will come off with the pillow block support.
 - b. With the wrench provided only remove the outer two jam nuts. **DO NOT TOUCH THE INNER TWO JAM NUTS.**
 - c. Remove the side plate and blade assembly. The blade can now be removed from the blade and side plate assembly and replaced.
 - d. Reverse this procedure for reassembly.

CAUTION: Before operating the machine again raise the tire mandrel arm and make sure that the blade will fit in the center of the mandrel groove.

8. REPAIR PARTS

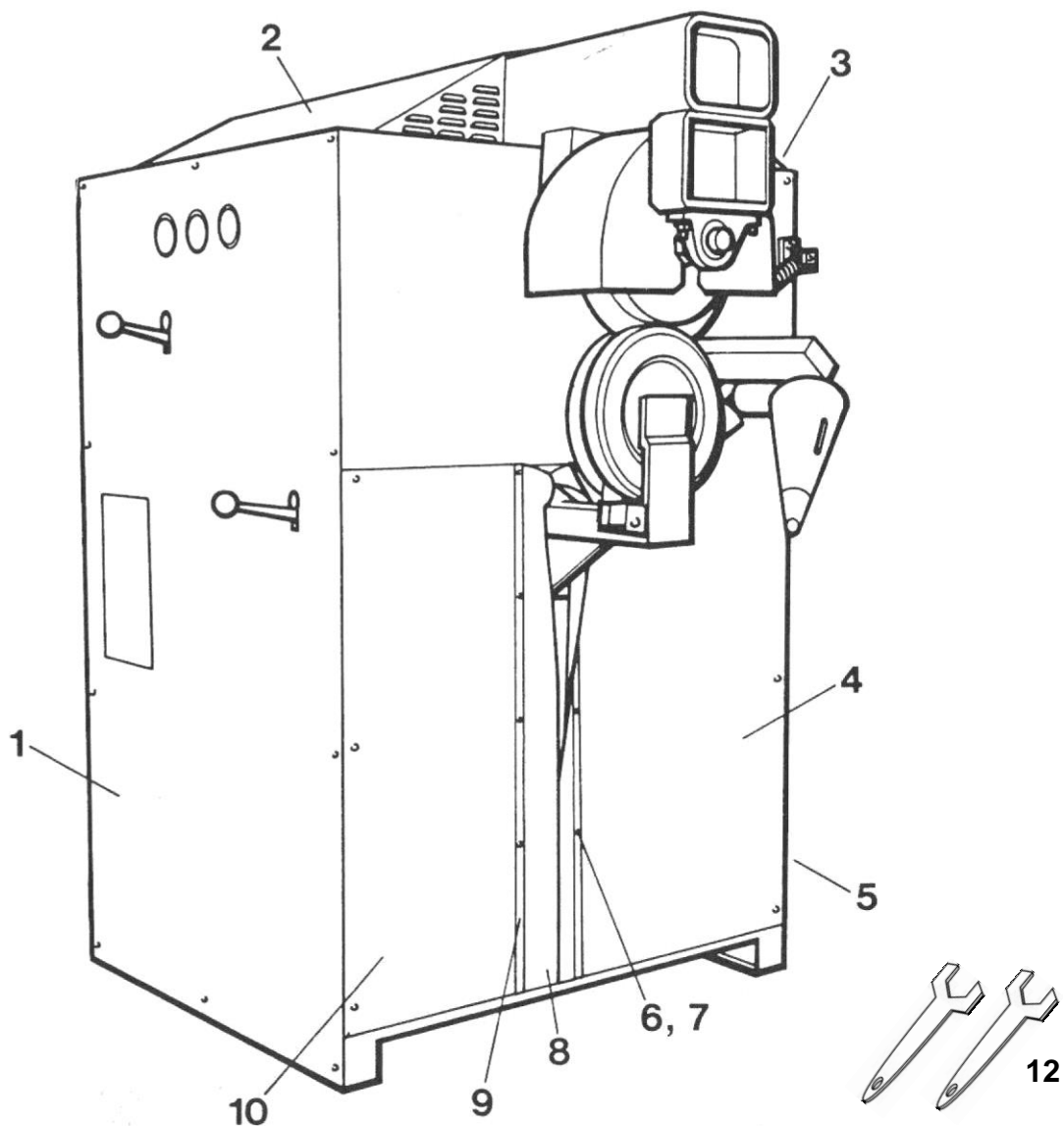

ITEM NO	PART NO	NO REQ	DESCRIPTION	ITEM NO	PART NO	NO REQ	DESCRIPTION
1	036-039	1	Front Panel	7	055-025	14	#10 NC Hex Nut
2	036-038	1	Front Top Panel	8	298-067	2	Shield
3	036-036	1	Rear Top Panel	9	111-477	2	Bracket
4	036-051	1	Right Right Side Panel	10	036-050	1	Left Right Side Panel
5	036-030	1	Rear Panel	11	028-148	48	1/4 NC x 50 Tapping Screw Type F (not shown)
6	028-179	14	#10 NC x 50 Slot Pan Hd Machine Screw	12	816-005	2	Wrenches

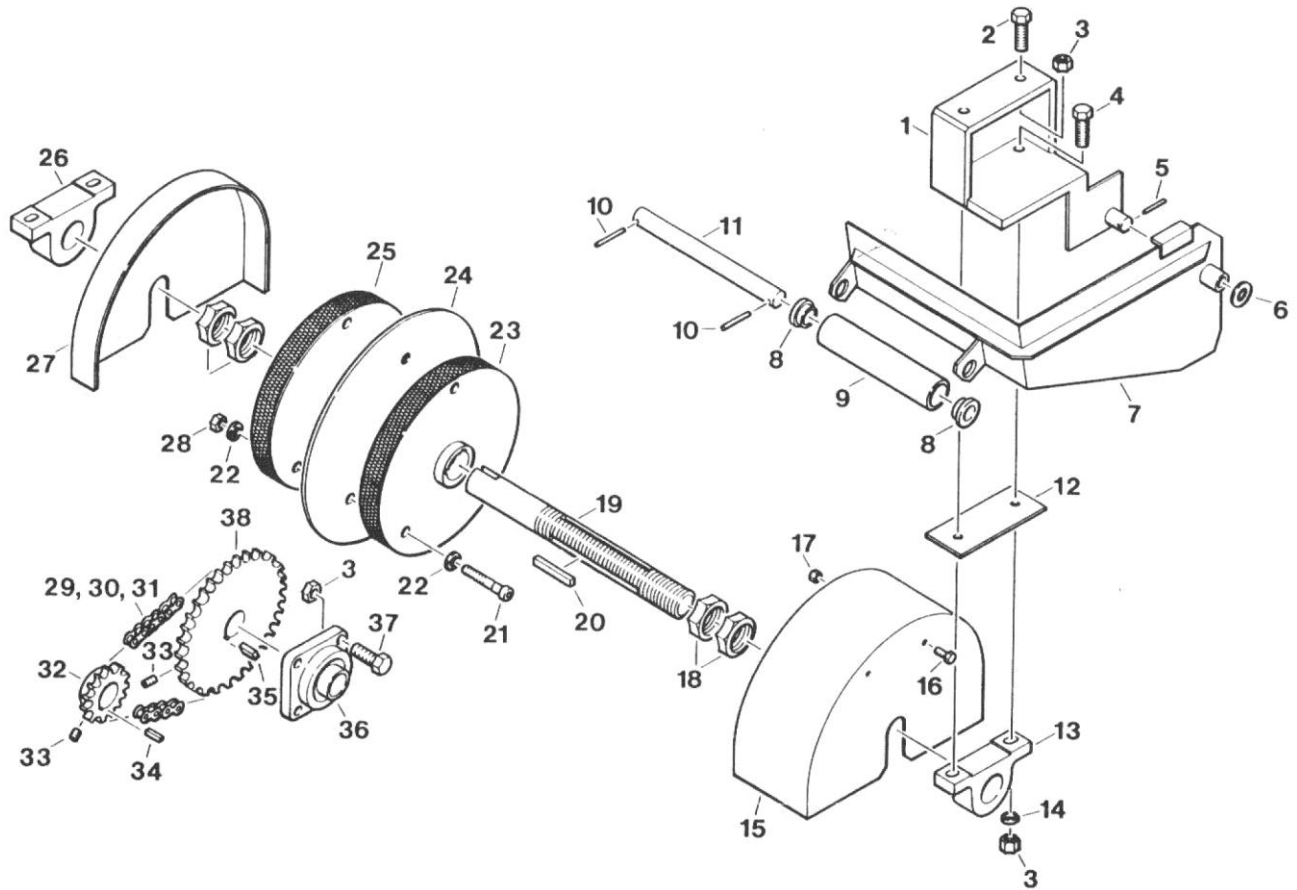

DRIVE BLADE AND SHIELD GROUP

ITEM NO	PART NO	NO REQ	DESCRIPTION	ITEM NO	PART NO	NO REQ	DESCRIPTION
1	878-037	1	Bracket	20	251-011	1	Key
2	028-006	2	Capscrew	21	028-154	3	Capscrew
3	055-026	10	Nut	22	108-015	6	Washer
4	028-023	4	Capscrew	23	101-430	1	Blade Plate
5	061-006	1	Pin	24	885-006	1	Blade
6	039-002	1	Bushing	25	101-387	1	Blade Plate
7	825-021	1	Blade Cover	26	107-095	1	Bearing
8	107-016	2	Bearing	27	298-066	1	Left Blade Shield
9	268-161	1	Roller	28	055-210	3	Nut
10	061-039	2	Pin	29	066-053	1	Chain
11	028-160	1	Roller Shaft	30	062-034	1	Connecting Link
12	186-089	as req'd	Spacer	31	062-036	1	Offset Link
13	107-096	1	Bearing	32	228-028	1	Sprocket
14	108-060	4	Washer	33	028-118	4	Set Screw
15	298-063	1	Right Blade Shield	34	251-036	1	Key
16	028-012	4	Capscrew	35	251-012	1	Key
17	055-009	4	Nut	36	107-027	1	Bearing
18	055-051	4	Nut	37	028-025	4	Capscrew
19	104-134	1	Driver Shaft	38	228-010	1	Sprocket

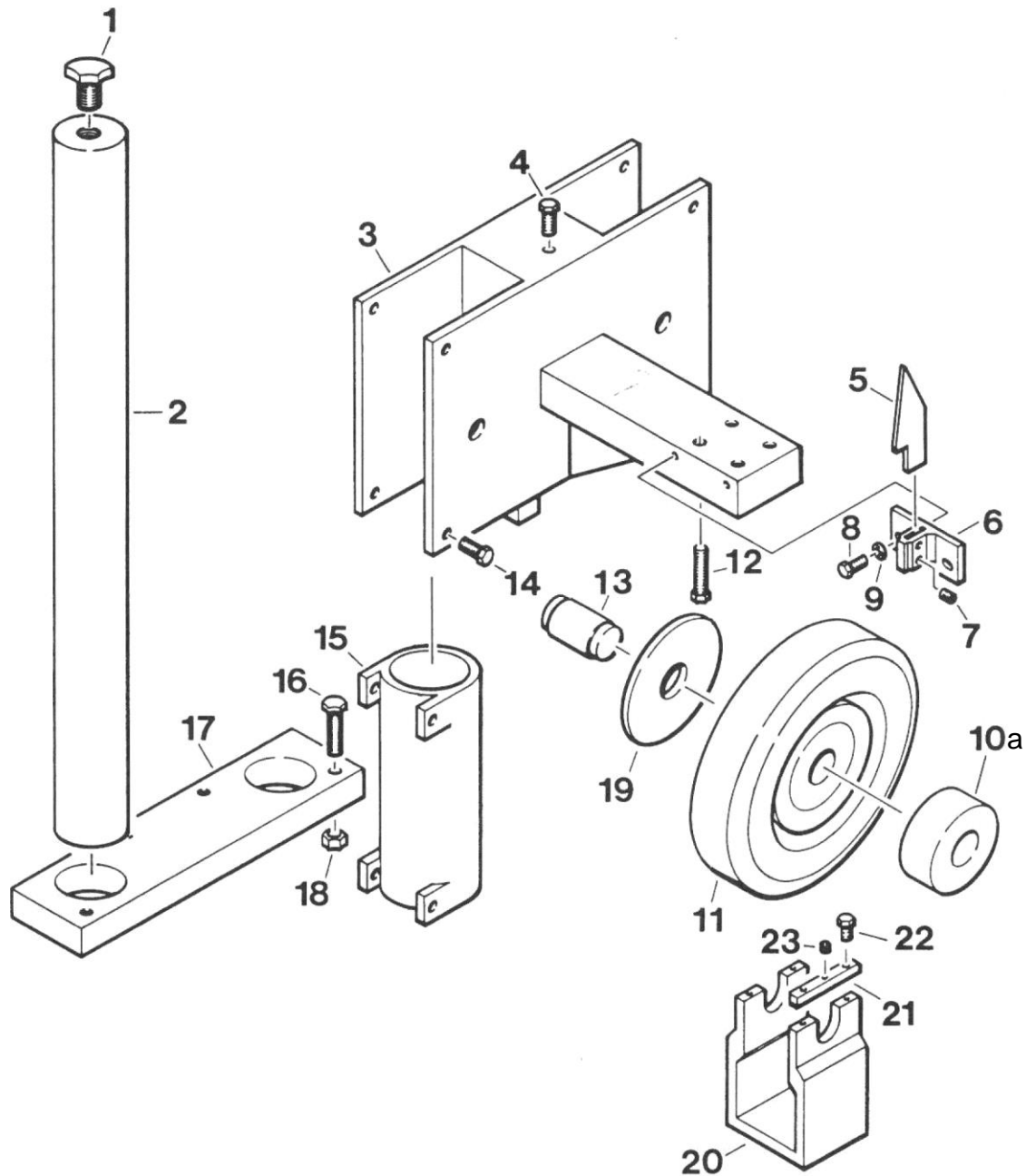

CARRIAGE AND PLATEN WHEEL GROUP

ITEM NO	PART NO	NO REQ	DESCRIPTION	ITEM NO	PART NO	NO REQ	DESCRIPTION
1	028-017	2	Cap screw	13	104-140	1	Platen Wheel Shaft
2	149-317	2	Rod	14	028-034	4	Cap screw
3	818-015	1	Carriage	15	936-011	2	Guide
4	028-025	1	Cap screw	16	028-089	4	Cap screw
5	885-049	1	Groove Cleaner Blade	17	190-224	1	Guide Block
6	878-038	1	Bracket	18	055-026	4	Nut
7	028-158	2	Set Screw	19	186-093	2	Spacer
8	028-021	2	Cap screw	20	878-049	1	Bracket
9	108-057	2	Washer	21	017-198	2	Strap
10a	107-031	2	Outer Bearing for Platen Wheel	22	028-014	4	Cap screw
10b*	107-032	2	Inner Bearing for Platen Wheel	23	028-158	2	Set screw
11	972-003	1	Platen Wheel with Bearings	24	096-271	4	Grease Zerk
12	028-181	4	Cap screw	25*	039-068	1	Brass Bushing

*Not Shown

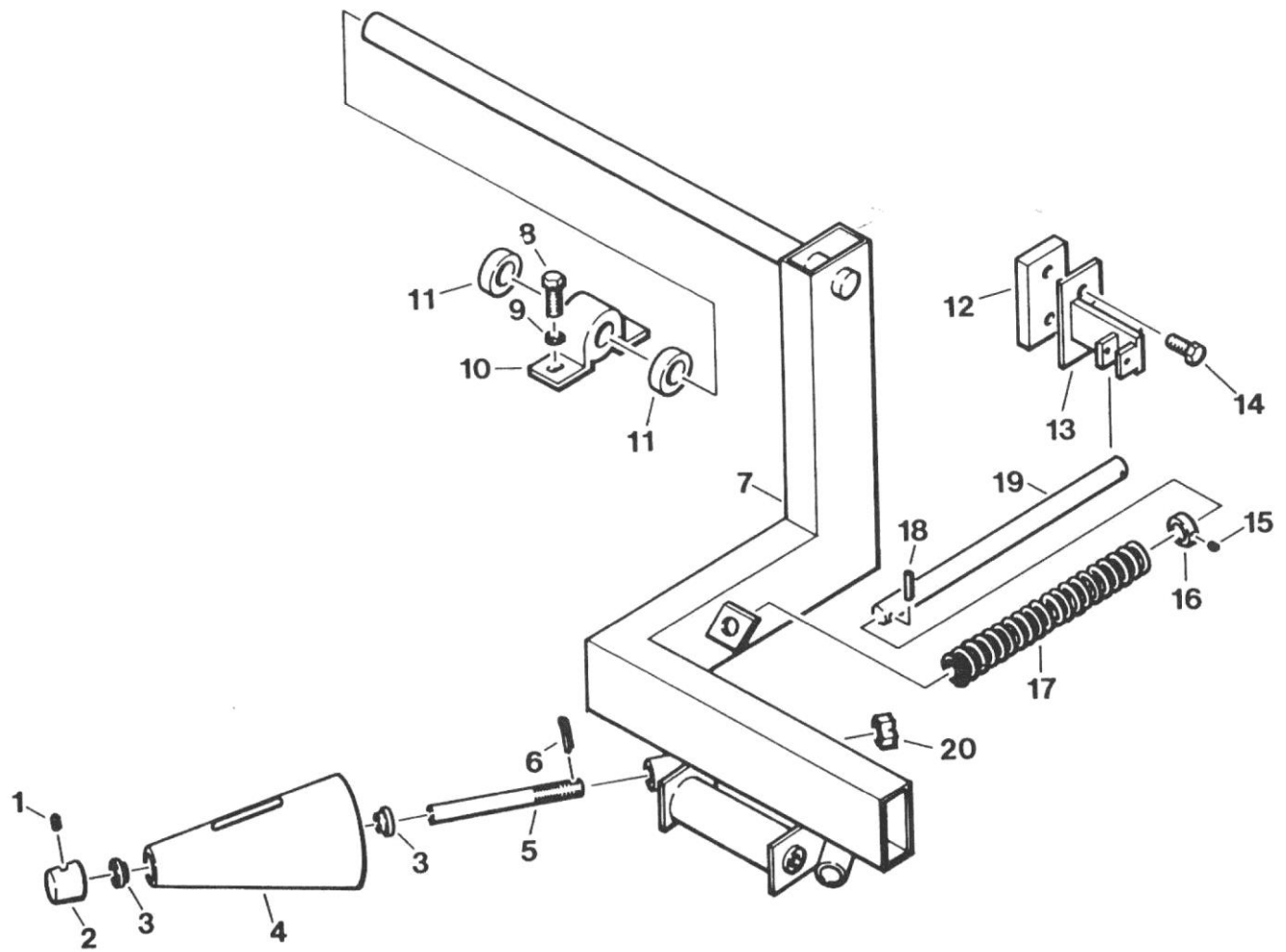

TIRE GUIDE

ITEM NO	PART NO	NO REQ	DESCRIPTION	ITEM NO	PART NO	NO REQ	DESCRIPTION
1	50-0006	2	Set Screw	11	489-053	2	Shaft Collar
2	281-005	2	Cone Point	12	186-088	1	Spacer
3	107-009	4	Bearing	13	950-516	1	Spring Rod Bracket
4	74-0264	2	Positioning Cone	14	028-021	2	Capscrew
5	104-038	2	Cone Shaft	15	028-029	1	Set Screw
6	061-015	2	Cotter Pin	16	489-016	1	Spring Guide Collar
7	834-082	1	Guide Frame	17	110-034	1	Return Spring
8	028-046	4	Capscrew	18	061-081	2	Pin
9	108-126	4	Washer	19	149-117	1	Spring Rod
10	020-107	2	Bearing	20	055-014	2	Castle Nut

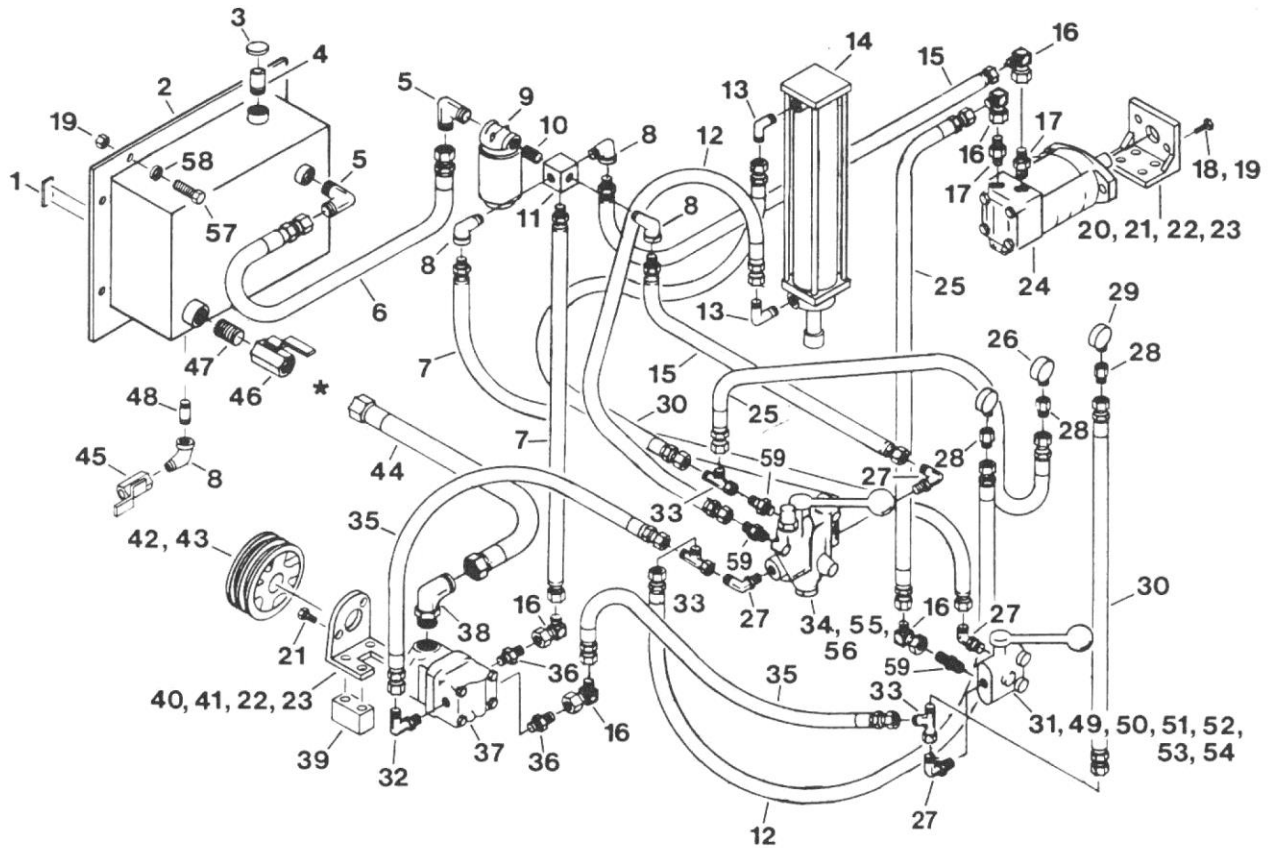

HYDRAULIC SYSTEM
BEGINNING WITH SERIAL NO. 88F120

ITEM NO	PART NO	NO REQ	DESCRIPTION	ITEM NO	PART NO	NO REQ	DESCRIPTION
1	023-023	1	Fluid Level Gauge	31	190-265	1	Rotate Valve
2	861-007	1	Reservoir	32	096-257	1	Straight Thread Elbow
3	098-110	1	Cap	33	096-358	3	Swivel Nut Run Tee
4	854-017	1	Neck	34	190-220	1	Lift Valve
5	096-356	1	Male Elbow	35	646-197	2	Hose
6	646-121	1	Hose	36	096-220	2	Straight Thread Connector
7	940-043	2	Hose	37	021-011	1	Pump
8	096-075	4	Street Elbow	38	096-264	1	Straight Thread Elbow
9	018-015	1	Filter	39	096-083	2	Spacer
10	096-018	1	Close Nipple	40	001-064	1	Mount
11	038-082	1	Filter Manifold	41	028-066	4	Capscrew
12	646-120	2	Hose	42	039-028	1	Bushing
13	096-262	2	Male Elbow	43	019-019	1	Sheave
14	030-035	1	Cylinder	44	646-117	1	Hose
15	940-042	2	Hose	45	190-248	1	Ball Valve
16	096-254	5	Swivel Nut Elbow	46	190-243	1	Ball Valve
17	096-259	2	Straight Thread Connector	47	096-357	1	Close Nipple
18	028-047	2	Capscrew	48	096-055	1	Nipple
19	055-156	10	Nut	49	061-178	1	Spring Pin
20	848-034	1	Motor Mount	50	062-074	1	Connecting Link
21	028-046	6	Capscrew	51	846-017	1	Link
22	108-126	8	Washer	52	837-018	1	Handle
23	055-154	8	Nut	53	028-050	5	Capscrew
24	259-027	1	Orbit Motor	54	055-009	5	Nut
25	646-115	2	Hose	55	028-181	6	Capscrew
26	023-016	2	Gauge	56	055-123	6	Nut
27	096-256	4	Male Elbow	57	028-034	8	Capscrew
28	096-359	3	Female Adaptor	58	108-060	8	Washer
29	023-026	1	Gauge	59	096-258	3	Male Connector
30	646-157	2	Hose				

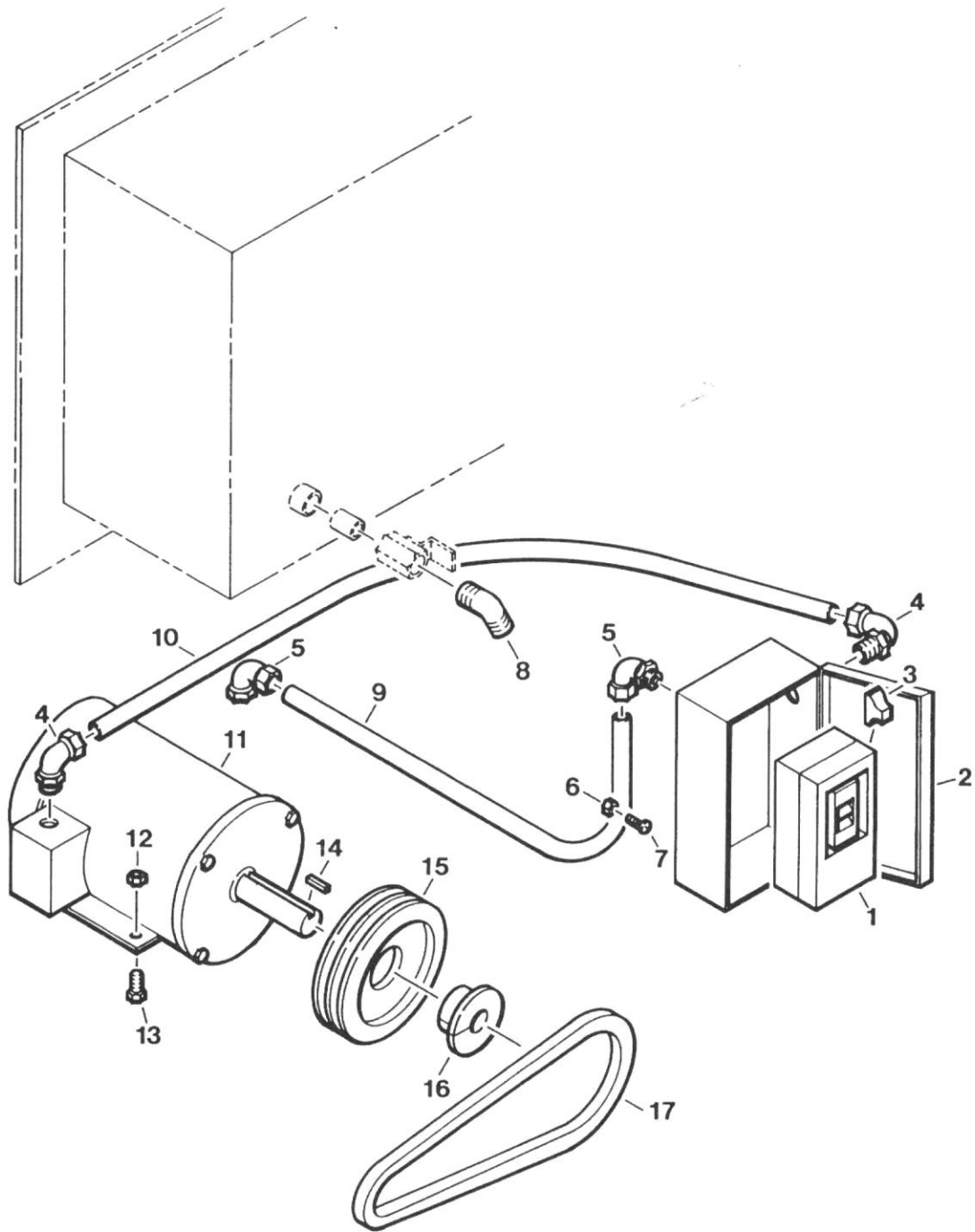

ELECTRICAL

ITEM NO	PART NO	NO REQ	DESCRIPTION	ITEM NO	PART NO	NO REQ	DESCRIPTION
1	980-244	1	Starter	11	259-041	1	Motor
2	980-245	1	Control	12	055-154	4	Nut
3	980-246	3	Heater	13	028-021	4	Capscrew
4	980-085	2	Connector	14	251-039	1	Key
5	980-067	2	Connector	15	019-019	1	Sheave
6	055-160	3	Nut	16	039-081	1	Bushing
7	028-257	3	Machine Screw	17	014-021	2	Belt
8	096-263	1	Male Elbow	18	646-116*	1	Hose
9	980-258	1	Conduit	19	036-034*	1	Left Panel
10	980-257	1	Conduit	20	028-148*	10	Tapping Screw

*Not Shown

Troubleshooting Guide

NOTE: There are three pressure gauges on the front of the machine to assist in troubleshooting. These are the lift input gauge, lift output gauge and the rotate gauge. These tests are not completely foolproof, they are designed as a guide to help narrow the possible area of concern. The only items necessary for a complete test are a 1/2" NPT pope plug and a 3/4" JIC to pipe fitting with the pipe port plugged with a minimum of 2000 PSI rating.

PROBLEM: CANNOT PENETRATE THE TIRE

Does valve gauge show approximately 1100 PSI in both the fully raised and fully lowered position?

NO: Could be leakage in the valve or cylinder. Raise the tire mandrel arm to achieve a reading on the cylinder gauge. Return the lever to neutral. There should be a maintained pressure reading after an initial drop.

YES: Probably a bad relief in the valve or a leaky piston seal. If a leakage internal to the cylinder is suspected, run the tire mandrel arm down until it bottoms out. Disconnect the bottom hose and fitting from the cylinder. Use test items to plug the hose and the bottom of the cylinder. Start the machine and try to run the tire mandrel arm down.

- 1) If both the cylinder gauges read approximately 1100 PSI the cylinder is bad, if less than 1100 PSI it is probably a bad valve.
- 2) If both gauges do not read approximately 1100 PSI it is likely a leaky spool in the valve.
- 3) If only one gauge is below 1100 PSI it is a damaged O-ring on the spool of the valve.

PROBLEM: ORBIT MOTOR STALLS

- 1) Was the correct oil added / installed in the oil reservoir?
 - a. Should be Mobil DTE24. Some oils will foam, indicated by a yellowish color in the oil, which will cause loss of power and could cause pump failure.
- 2) Does the orbit gauge show pressure when the lift handle is in neutral?
 - a. When in neutral there should be no pressure reading on the orbit gauge. If there is pressure there is a restriction between the valve and the filter.
- 3) Does the pressure drop off and the motor stall when cutting?
 - a. If so there is a problem with the tire mandrel arm motor.
- 4) Is the relief hose from the orbit valve to the filter warmer than the motor supply hose?

NOTE: THIS REQUIRES REMOVAL OF A PANEL. OBSERVE ALL PRECAUTIONS AND WARNINGS WHEN PERFORMING THIS CHECK.

- a. If it is warmer than the motor supply hose the relief has probably opened inside the valve. If the motor to filter hose is warmer at stall the motor poppet valve may be faulty.
- 5) If all other tests have failed to determine the problem the following procedure can be used to isolate the orbit motor problem.
 - a. Using a 3/4" JIC to pipe fitting with the pipe end plugged, install it at the orbit motor end of the valve to motor hose. Run the machine with the valve on. If you get 2000 PSI on the gauge the motor is bad. If you are not getting 2000 PSI reconnect the hose to the motor.
 - b. Install the same plug set-up between the orbit motor gauge and the valve and run the machine with the valve on. If you get 2000 PSI the valve is bad. If you do not get 2000 PSI the pump is bad.

COMMERCIAL WARRANTY

This product is warranted by BRANICK INDUSTRIES, INC. to the original user-owner against defective materials or workmanship for a period of one year from the date of shipment. During the warranty period, at the discretion of Branick management, if the product is found to be defective, it will be repaired or replaced without charge. For service, contact Branick (800-437-4394) to obtain an RMA. Any product shipped to Branick must have an RMA and proof of original shipment date. The repaired or replacement product will be returned with transportation charges prepaid by Branick.

This warranty does not cover defects in the product caused by ordinary wear and tear, abuse, misuse, overloading, accident (including shipping damage), improper maintenance, alteration, or any other cause not the result of defective materials or workmanship.

REPAIR OR REPLACEMENT IS THE EXCLUSIVE REMEDY FOR DEFECTIVE PRODUCT UNDER THIS WARRANTY. THIS WARRANTY IS EXPRESSLY IN LIEU OF ALL OTHER WARRANTIES, INCLUDING ANY IMPLIED WARRANTY OF MERCHANT ABILITY OR ANY IMPLIED WARRANTY OF FITNESS FOR A PARTICULAR PURPOSE OF THIS PRODUCT. BRANICK INDUSTRIES, INC. SHALL NOT BE LIABLE FOR ANY CONSEQUENTIAL OR INCIDENTAL DAMAGES.

BRANICK INDUSTRIES, INC. reserves the right to make changes in the design or construction of our products without obligation to incorporate such changes in products already sold and without notice.

Service parts and regular repair service are available from authorized distributors of Branick products, or from:

BRANICK INDUSTRIES, INC.
4245 Main Ave.
Fargo, North Dakota 58103
Toll Free: 800-437-4394



www.branick.com