

# Branick®

## Tire Handling Equipment

## Repair Parts Information

B-Inverter Type Spreader

MODEL B-INV

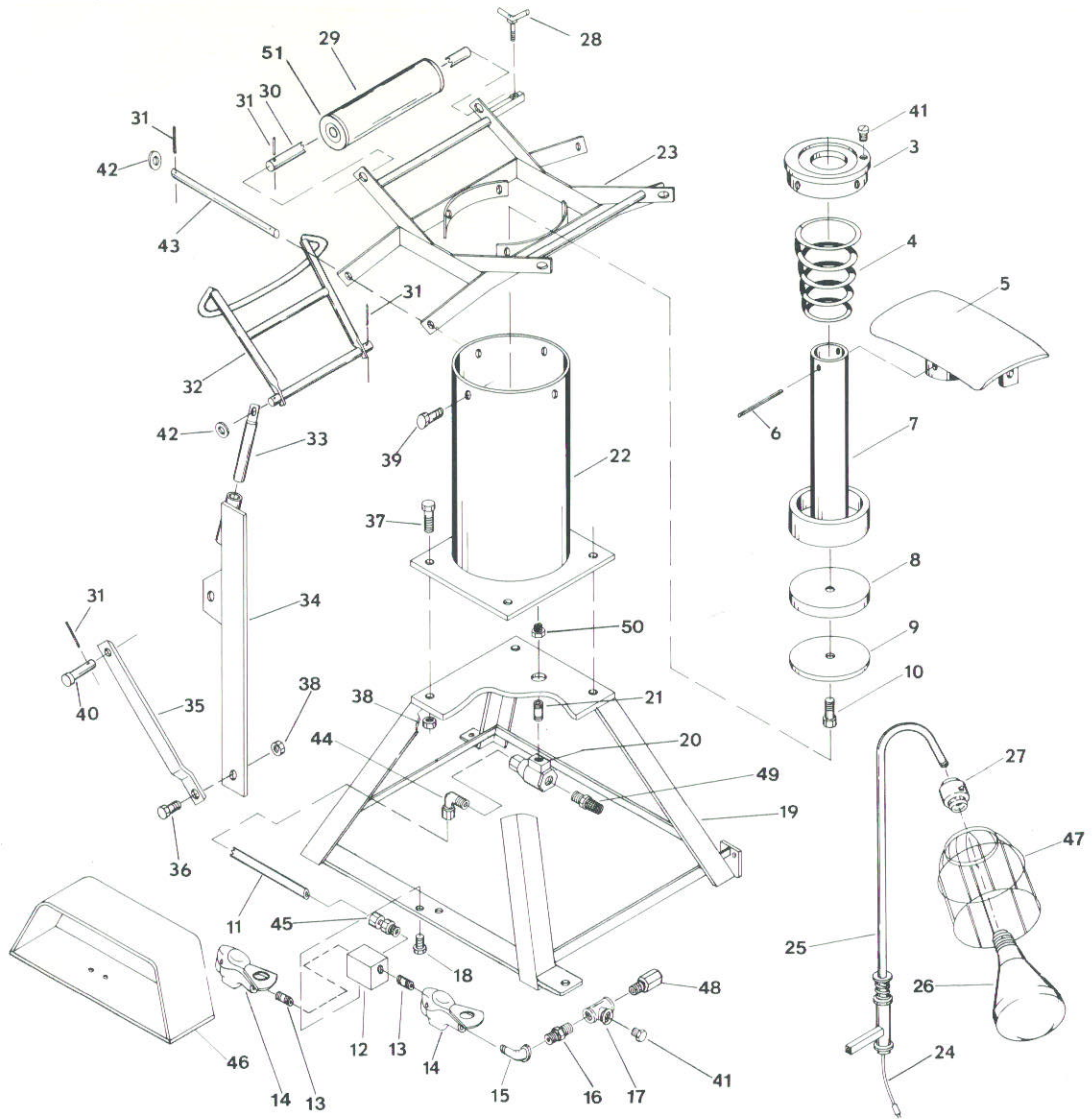

ITEM NO.	PART NO.	NO. REQ'D	DESCRIPTION	ITEM NO.	PART NO.	NO. REQ'D	DESCRIPTION
3	50.098	1	Cover Plate	29	15.963	2	Tire Rollers
4	1.110	1	Compression Spring	30	19.104	2	Roller Shaft
5	4.264	1	Inverting Head	31	5.061	8	1/8" x 1" Drive Pin
6	171.061	1	1/4" x 3" Drive Pin	32	268.950	2	Bead Hooks
7	4.855	1	Piston & Rod Assembly	33	203.950	4	Hook Slide
8	26.041	1	Piston Cup - 5 5/8 Dia.	34	285.950	2	L. H. Hook Arms
9	21.108	1	Piston Cup Washer		284.950	2	R. H. Hook Arms
10	239.028	1	9/16" x 1 1/4" NC HHCS	35	10.062	2	R. H. Offset Link
11	82.646	1	3/8" Nylon Tube x 19"		11.062	2	L. H. Offset Link
12	2.847	1	Valve Manifold	36	283.028	4	1/2" x 3/4" HHCS
13	221.096	2	1/4" Close Nipple	37	85.028	4	1/2" x 1 7/8" HHCS
14	280.950	2	Valve Assembly	38	38.055	8	1/2" Lock Nut
15	38.096	1	1/4" St. Elbow - 90°	39	54.028	4	7/16" x 1 NC HHCS
16	162.096	1	1/4" Hex Nipple (Restricted)	40	14.003	4	5/8" x 2" Pin
17	249.096	1	1/4" - 1/4" - 1/4" Pipe Tee	41	4.096	2	1/4" Pipe Plug
18	12.028	2	5/16" x 3/4 HHCS	42	22.108	8	5/8 Std. Washer
19	30.834	1	Base Assembly	43	20.104	2	Shaft - 9 1/4" Long
20	85.190	1	Exhaust Valve	44	146.096	1	1/4" - 3/8" Tube Elbow
21	96.096	1	1/4" x 1 3/4" Pipe Nipple	45	163.096	1	1/4" - 3/8" Male Connector
22	4.828	1	5 5/8 Dia. Cylinder	46	1.835	1	Foot Valve Guard
23	31.834	1	Roller Frame	47	39.298	1	Plastic Lamp Guard
24	8.980	1	10 Ft. Cord With Plug	48	1.932	1	Filter Screen Assembly
25	59.900	1	Light Post Assembly	49	35.885	1	Muffler
26	6.376	1	75 Watt Bulb	50	39.096	1	3/8" - 1/4" Pipe Bushing
27	57.980	1	Socket	51	59.107	4	Bearing
28	281.950	1	Wing Screw				

# PARTS LIST — B-INVERTER LIFT ATTACHMENT

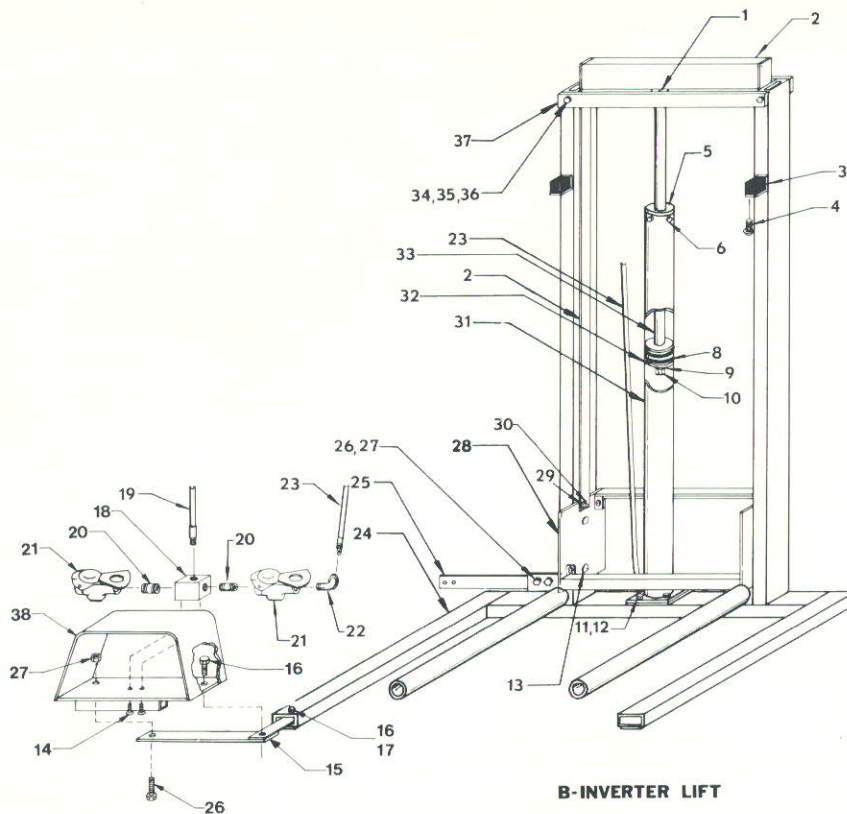

**B-INVERTER LIFT**

ITEM NO.	PART NO.	NO. REQ'D	DESCRIPTION	ITEM NO.	PART NO.	NO. REQ'D	DESCRIPTION
1	ND 47.061	1	1/4" x 1" Drive Pin	20	ND 221.096	2	1/4" Close Nipple
2	ND 327.950	1	Lift Bracket Assembly	21	ND 280.950	2	Valve Assembly
3	ND 13.267	2	1" x 1" x 1" Rubber Cushion	22	ND 23.096	1	1/4" - 90° St. Elbow
4	ND 114.028	2	1/4" x 3/4" RD. HD. Bolt	23	ND 358.950	1	24" Hose Assembly
5	ND 26.098	1	Cylinder Cover Plate	24	ND 62.900	1	Frame Assembly
6	ND 280.028	3	5/16" x 1/2" HHCS	25	ND 141.111	1	Rear Connector
8	ND 6.044	2	2" V Piston Rings	26	ND 287.028	3	3/8" x 7/8" NC HHCS
9	ND 240.167	1	14 Mil Gasket	27	ND 210.055	3	3/8" NC Hex Lock Nut
10	ND 239.028	1	9/16" x 1 1/4" NC HHCS	28	ND 330.950	1	Fork Lift
11	ND 4.055	4	1/4" Hex Lock Nut	29	ND 9.108	2	1/2" Plain Washer
12	ND 41.028	4	1/4" x 1" HHCS	30	ND 5.061	2	1/8" x 1" Drive Pin
13	ND 42.013	8	Nylon Slide Buttons	31	ND 329.950	1	Cylinder
14	ND 138.028	2	5/16" x 1/2" Flat HD. Screw	32	ND 10.051	1	2" Piston
15	ND 332.950	1	Front Connector	33	ND 72.149	1	Piston Rod
16	ND 15.028	2	3/8" x 1/2" NC HHCS	34	ND 50.028	2	5/16" x 3" NC HHCS
17	ND 14.108	1	3/8" Lock Washer	35	ND 25.108	2	5/16" Plain Washer
18	ND 2.847	1	Valve Manifold	36	ND 2.055	2	5/16" NC Hex Nut
19	ND 357.950	1	35" Hose Assembly	37	ND 146.111	2	Lift Brackets
				38	ND 4.835	1	Foot Pedal Guard

## COMMERCIAL WARRANTY

This equipment is warranted by BRANICK INDUSTRIES, INC. to the original commercial user-owner against defective materials or workmanship for a period of one year from the date of delivery, except for Models BTJ, EL-200, TTB, ALJ, PHJ, TTC, DWL, FTB-H, FTB-M, TC, PTS, PS-1, TWG, EMB-10 and TD, which are warranted for ninety (90) days. During the warranty period, equipment found to be defective will be repaired or replaced (at the warrantor's option) without charge. The equipment must be returned, transportation charges prepaid, with proof of delivery date to BRANICK INDUSTRIES, INC., Fargo, North Dakota 58102. The repaired or replaced equipment will be returned with transportation charges prepaid by Branick.

This warranty does not cover defects in the equipment caused by ordinary wear and tear, abuse, misuse, overloading, accident (including shipping damage), improper maintenance, alteration, use of improper fluids, or any other cause not the result of defective materials or workmanship.

REPAIR OR REPLACEMENT IS THE EXCLUSIVE REMEDY FOR DEFECTIVE EQUIPMENT UNDER THIS WARRANTY. THIS WARRANTY IS EXPRESSLY IN LIEU OF ALL OTHER WARRANTIES, INCLUDING ANY IMPLIED WARRANTY OF MERCHANTABILITY OR ANY IMPLIED WARRANTY OF FITNESS FOR A PARTICULAR PURPOSE ON THIS EQUIPMENT. BRANICK INDUSTRIES, INC. SHALL NOT BE LIABLE FOR ANY CONSEQUENTIAL OR INCIDENTAL DAMAGES FOR BREACH OF ANY EXPRESS OR IMPLIED WARRANTY ON THIS EQUIPMENT.

Service parts are available from Branick distributors. Contact Branick in Fargo for the location of your nearest distributor.

BRANICK INDUSTRIES, INC.  
2600 3rd Avenue North  
Box 1937  
Fargo, North Dakota 58107  
701/235-4446 TLX 29-2223

Branick Industries, Inc. reserves the right to make changes in design or construction of equipment without obligation to incorporate such changes in equipment previously sold.

BRANICK INDUSTRIES, INC.  
2600-3rd Avenue North, Box 1937  
Fargo, North Dakota 58107  
701-235-4446 TLX 29-2223

FPS-123-4-71-6  
(Rev. 1-87)

# Branick®

Printed in U.S.A.



## Tire Handling Equipment

## Operating Instructions

B-Inverter Tire Spreader

**MODEL B-INV**

### OPERATING INSTRUCTIONS

Set tire on rollers. Drop hooks into tire and adjust hook height to tire bead. Hooks should be slightly above level. Press on foot valve to spread and invert.

To rotate tire to new position, release air and turn tire on rollers.

The light bracket may be adjusted to the most favorable position.

### MAINTENANCE

Every six (6) months, the Cylinder should be cleaned and re-oiled. To do this remove No. 10.062 and No. 11.062 Offset Links and No. 4.264 Inverter Head. Remove four (4) No. 54.028 Bolts. The Cover Plate No. 8.090 and Piston and Rod can now be removed. Clean out Cylinder thoroughly and oil. After replacing Rod and Piston, put in ¼ cup of No. 20 oil.

Oil all hinge points weekly.

### COMMERCIAL WARRANTY

This equipment is warranted by BRANICK MFG., INC. to the original commercial user-owner against defective materials or workmanship for a period of one year from the date of delivery, except for Models BTJ, EL-200, EL-250, EL-500, ALJ, PHJ, BCL, TTC, DWL, FTB-A/H, FTB-H, FTB-M, EMB-10, EMB-10/PP, TD, and RSL, which are warranted for ninety (90) days. During the warranty period, equipment found to be defective will be repaired or replaced (at the warrantor's option) without charge. The equipment must be returned, transportation charges prepaid, with proof of delivery date to BRANICK MFG., INC., Fargo, North Dakota 58102. The repaired or replaced equipment will be returned with transportation charges prepaid by Branick.

This warranty does not cover defects in the equipment caused by ordinary wear and tear, abuse, misuse, overloading, accident (including shipping damage), improper maintenance, alteration, use of improper fluids, or any other cause not the result of defective materials or workmanship.

REPAIR OR REPLACEMENT IS THE EXCLUSIVE REMEDY FOR DEFECTIVE EQUIPMENT UNDER THIS WARRANTY. THIS WARRANTY IS EXPRESSLY IN LIEU OF ALL OTHER WARRANTIES, INCLUDING ANY IMPLIED WARRANTY OF MERCHANTABILITY OR ANY IMPLIED WARRANTY OF FITNESS FOR A PARTICULAR PURPOSE ON THIS EQUIPMENT. BRANICK MFG., INC. SHALL NOT BE LIABLE FOR ANY CONSEQUENTIAL OR INCIDENTAL DAMAGES FOR BREACH OF ANY EXPRESS OR IMPLIED WARRANTY ON THIS EQUIPMENT.

WHEN THE QUESTION OF WARRANTY CLAIMS ARISE, CONTACT BRANICK FACTORY AT FARGO, NORTH DAKOTA.

Service parts, warranty, and regular repair service for products are available from Branick.

Should you require assistance, please contact:

BRANICK INDUSTRIES, INC.  
2600-3rd Avenue North, Box 1937  
Fargo, North Dakota 58107  
701-235-4446 TLX 29-2223

BRANICK INDUSTRIES, INC.  
2600-3rd Avenue North, Box 1937  
Fargo, North Dakota 58107

FIS-118-471-6  
(Rev. 8-83)



Printed in U.S.A.