



**MODEL 5035  
TIRE SPREADER**

Repair Parts  
Information



Branick Industries, Inc. • 4245 Main Avenue • Fargo, North Dakota 58103

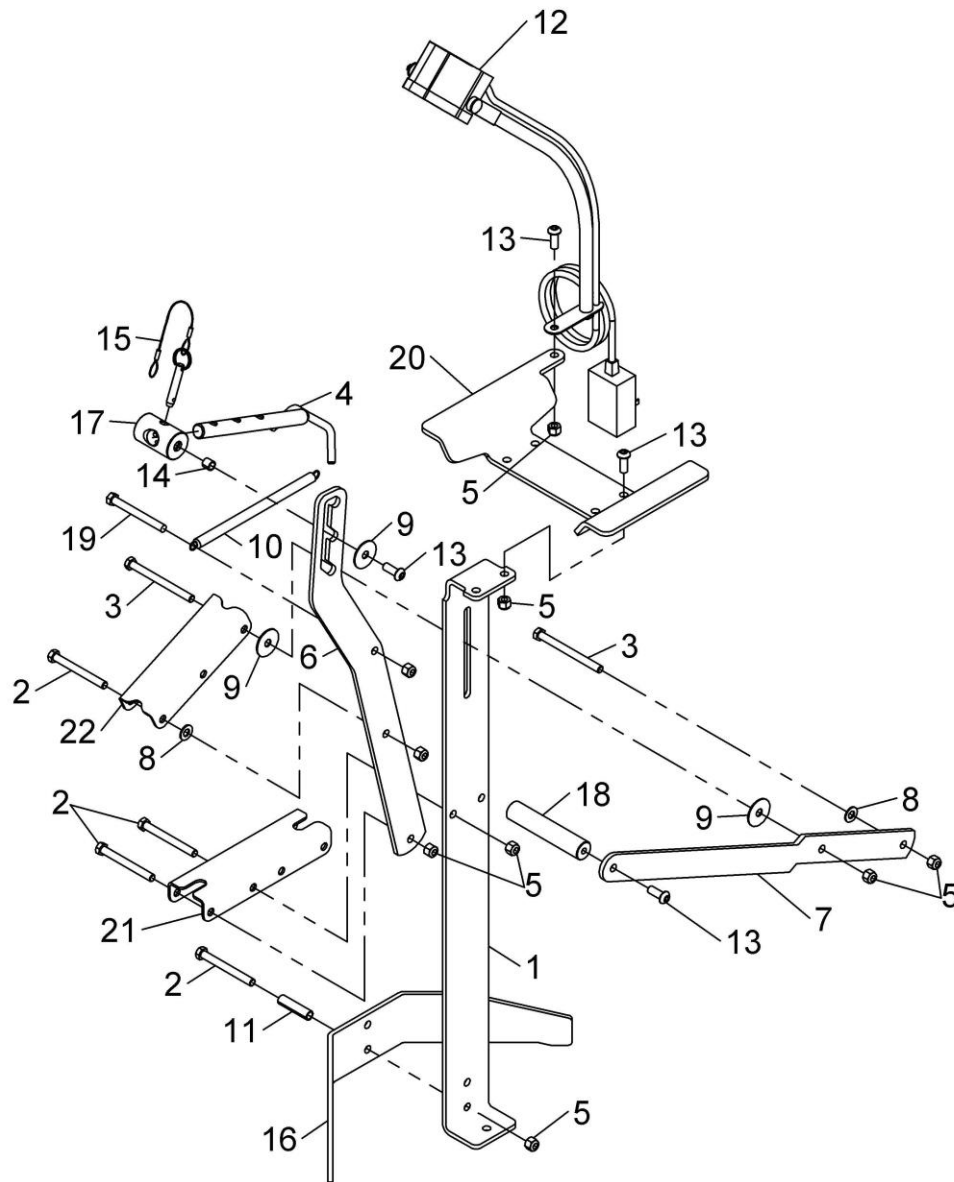

| ITEM NO. | PART NO. | NO. REQ'D | DESCRIPTION           | ITEM NO. | PART NO. | NO. REQ'D | DESCRIPTION                        |
|----------|----------|-----------|-----------------------|----------|----------|-----------|------------------------------------|
| 1        | 013-092  | 2         | SPREADER GUIDE        | 12       | 09-0020  | 1         | LED LIGHT                          |
| 2        | 028-122  | 7         | 3/8 X 3-1/2 HHC SCREW | 13       | 50-0167  | 11        | 3/8 X 1 BHC SCREW                  |
| 3        | 50-0182  | 2         | 3/8 X 4-1/4 HHC SCREW | 14       | 52-0053  | 4         | 7/16" SPACER                       |
| 4        | 03-0522  | 2         | SPREAD HOOK           | 15       | 54-0051  | 2         | QUICK RELEASE PIN                  |
| 5        | 055-154  | 16        | 3/8 NYLOCK NUT        | 16       | 636-049  | 2         | LEG                                |
| 6        | 06-0110  | 4         | SPREAD ARM            | 17       | 73-1111  | 2         | ADJUSTMENT BLOCK                   |
| 7        | 06-0112  | 2         | SPREAD HANDLE         | 18       | 73-1112  | 1         | PULL HANDLE                        |
| 8        | 108-015  | 4         | 3/8 FLAT WASHER       | 19       | 50-0183  | 2         | 3/8 X 3-1/2 HHC SCREW FULL THREADS |
| 9        | 108-141  | 8         | 3/8 FENDER WASHER     | 20       | 71-0395  | 1         | TIRE REST                          |
| 10       | 110-083  | 1         | SPRING                | 21       | 72-0533  | 1         | ARM PIVOT                          |
| 11       | 268-545  | 2         | 2" SPACER             | 22       | 72-0534  | 1         | SPREAD LINKAGE                     |

**Storage Cabinet**

The optional storage cabinet fits both the 5035 and 5045. It provides ample room to hold buffer, plugs, patches and anything else you need to perform tire repairs right at the spreader. Simple two bolt installation. All steel construction ensures long life and durability.

Part Number: 05-0056

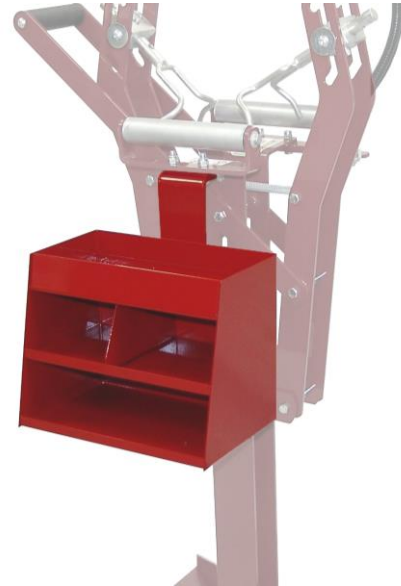

**Riser Base**

The optional riser provides an additional 3 inches of lift to provide a more comfortable working height for taller individuals. All steel construction with pre-drilled floor mount holes. Installation takes only minutes.

Part Number: 05-0121



## COMMERCIAL WARRANTY

This product is warranted by BRANICK INDUSTRIES, INC. to the original user-owner against defective materials or workmanship for a period of one year from the date of shipment. During the warranty period, at the discretion of Branick management, if the product is found to be defective, it will be repaired or replaced without charge. For service, contact Branick (800-437-4394) to obtain an RMA. Any product shipped to Branick must have an RMA and proof of original shipment date. The repaired or replacement product will be returned with transportation charges prepaid by Branick.

This warranty does not cover defects in the product caused by ordinary wear and tear, abuse, misuse, overloading, accident (including shipping damage), improper maintenance, alteration, or any other cause not the result of defective materials or workmanship.

REPAIR OR REPLACEMENT IS THE EXCLUSIVE REMEDY FOR DEFECTIVE PRODUCT UNDER THIS WARRANTY. THIS WARRANTY IS EXPRESSLY IN LIEU OF ALL OTHER WARRANTIES, INCLUDING ANY IMPLIED WARRANTY OF MERCHANT ABILITY OR ANY IMPLIED WARRANTY OF FITNESS FOR A PARTICULAR PURPOSE OF THIS PRODUCT. BRANICK INDUSTRIES, INC. SHALL NOT BE LIABLE FOR ANY CONSEQUENTIAL OR INCIDENTAL DAMAGES.

BRANICK INDUSTRIES, INC. reserves the right to make changes in the design or construction of our products without obligation to incorporate such changes in products already sold and without notice.

Service parts and regular repair service are available from authorized distributors of Branick products, or from:

BRANICK INDUSTRIES, INC.  
4245 Main Ave.  
 Fargo, North Dakota 58103  
Toll Free: 800-437-4394



[www.branick.com](http://www.branick.com)