



MODEL 5500  
Tire Repair  
Station

Installation, Operation  
and Repair Parts  
Information

---



Branick Industries, Inc. • 4245 Main Ave • P.O. Box 1937 • Fargo, North Dakota 58103

## TABLE OF CONTENTS

---

SAFETY INSTRUCTIONS	1
DEFINITIONS	1
INSTALLATION INSTRUCTIONS	2
OPERATING INSTRUCTIONS	2
MAINTENANCE INSTRUCTIONS	2
REPAIR PARTS	3-8
REPAIR PARTS LIST	4-8
WARRANTY	11

## SAFETY INSTRUCTIONS

---

- NEVER allow unauthorized personnel to operate this product.
- NEVER use this product for anything other than its intended use.
- THOROUGHLY train new employees in the proper use and care of this product.
- PROHIBIT unauthorized personnel from being in shop area while this product is in use.

## DEFINITIONS

---

- **CAUTION:** Indicates a potentially hazardous situation, which if not avoided, may result in damage to property or minor personal injury.
- **HAZARD:** A source of potential injury to a person.
- **MAINTENANCE:** Those actions that preserve the correct and proper conditions under which the machine shall be used. This may include adjustment, replacement of wear items, lubrication and cleaning, but not modifications or repair of damage.
- **MAY:** This word is understood to be permissive.
- **MUST:** This word is understood to be mandatory.
- **OPERATION:** The correct and proper use of the machine as described in this manual.
- **SAFETY ALERT SYMBOL:** A symbol that indicates a potential personal safety hazard. It is composed of an equilateral triangle surrounding an exclamation point.
- **SHALL:** This word is understood to be mandatory.
- **SHOULD:** This word is understood to be advisory.
- **WARNING:** Indicates a potentially hazardous situation, which if not avoided, may result in death or serious personal injury.

## CAUTION

- ◆ Before using this product, read and fully understand the operating instructions and all decals on the product. This is necessary to prevent injury to the operator and damage to the product.
- ◆ Use this product only for lifting, spreading and repairing tire casings. Do not use this product for any other purpose.
- ◆ Keep fingers and hands clear of spread hooks during tire spread.
- ◆ Do not use this product if it is visibly worn, distorted or damaged.
- ◆ Always wear appropriate eye protection.

## WARNING

- ◆ Keep feet clear of the tire ramp and scissor arms when raising and lowering spreader platform.
- ◆ All personnel must be clear of the tire lift area during operation.

### **INSTALLATION**

---

- 1) Attach the tire ramp (item 45) and retractor bar (item 46) to the Model 5500 with hardware provided. Tighten nylon lock nuts enough to allow free rotation at pivot points (see page 2)
- 2) Position the Model 5500 on a solid level floor leaving a minimum of 36 inches of clearance on operation sides and 24 inches of clearance on valve tray side.
- 3) Attach a 1/4 NPT quick coupler nipple (not provided) into the fitting located on lower frame on valve tray side of machine. Use 1/4 inch air hose with 100 p.s.i. minimum.

### **OPERATION**

---

- 1) Make sure the spreader platform is in the lowest position.
- 2) Pull the spread hook arms out into the upright position.
- 3) Roll the tire up the ramp and onto the spreader platform rollers. Steady tire with hand and insert spread hooks between tire beads.
- 4) Raise the spreader platform to comfortable working height using the platform lift foot valve.
- 5) Adjust spread hooks to proper height for the tire size being repaired. The spread hook arms are held in position with a hitch pin. To adjust the spread hook arms, pull the hitch pin and move spread hook arm up or down to one of the four adjustment holes. Most larger truck tires will use the uppermost adjustment holes. Both spread hook arms must be adjusted to the same height.
- 6) Spread tire to desired width using the hand operated valve attached to accessory tray. If tire is lifted off tire rollers when it is spread, the spread hook arms are positioned too high and should be lowered.
- 7) After tire repairs are complete, lower the spreader platform to lowest position.
- 8) Remove spread hook arm pressure and remove spread hook arms from the tire bead.
- 9) Standing at the end of the ramp, pull the tire down the ramp using both hands.

### **MAINTENANCE**

---

**Monthly:** On the spread cylinder, remove the slotted plug from the tee fitting at the end of cylinder and put in a few ounces of 10 or 20 weight oil. On the lift cylinder, put few ounces of oil in the 1/4 inch hole in top cover plate.

**REPAIR PARTS**

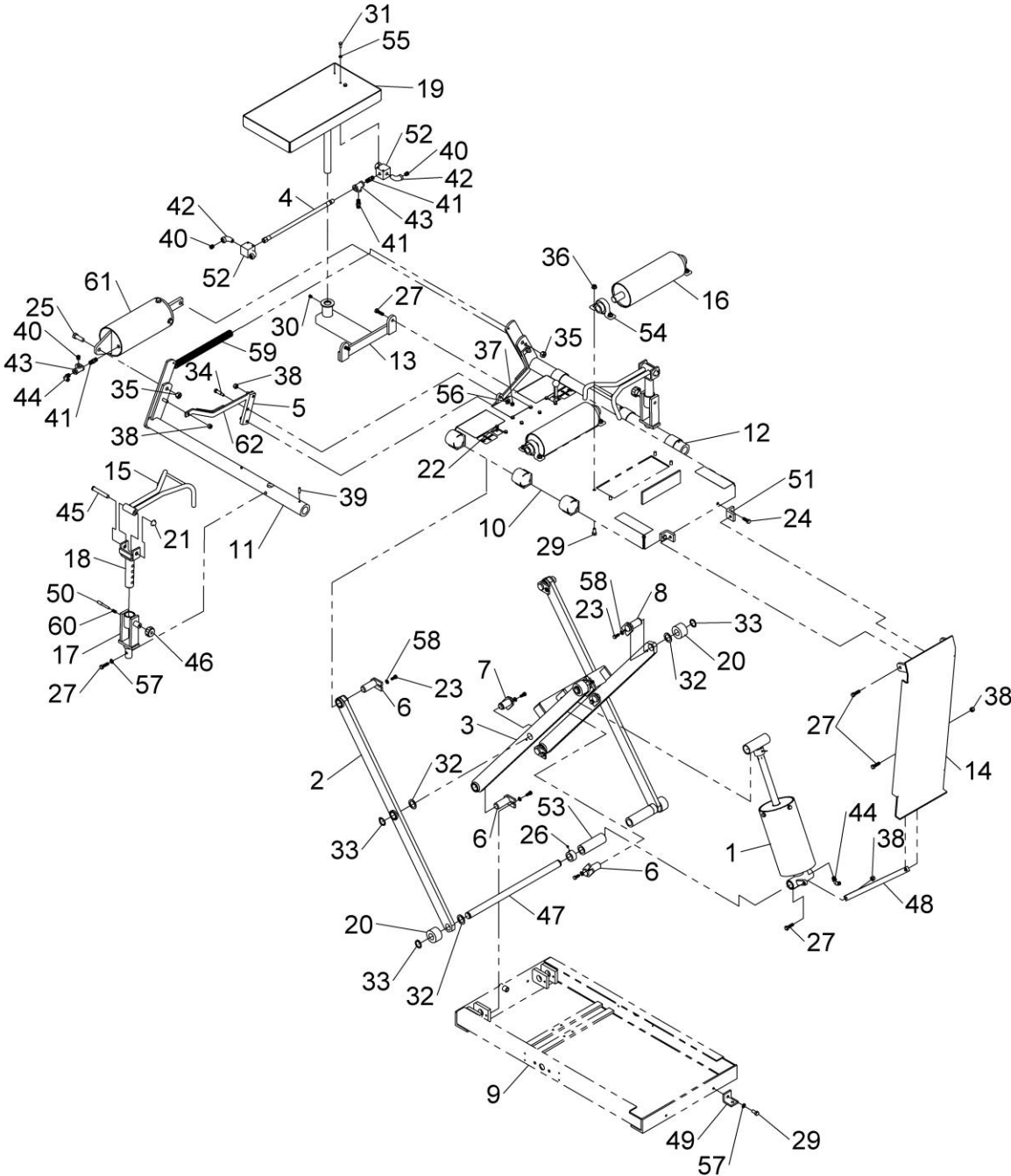

**Main Assembly**

ITEM	QTY	PART NO.	DESCRIPTION
1	1	01-0179	5-1/4" LIFT CYLINDER
2	2	01-0182	OUTSIDE ARM
3	1	01-0183	INSIDE ARM
4	1	01-0201	SHORT HOSE ASSEMBLY
5	1	03-0036	PIVOT LINK
6	6	03-0106	PIVOT PIN
7	2	03-0107	PIVOT PIN
8	2	03-0108	ROLLER ROD
9	1	03-0243	BASE FRAME
10	1	03-0247	SPREADER PLATFORM
11	1	03-0248	FRONT POWER ARM
12	1	03-0249	REAR POWER ARM
13	1	03-0250	TOOL TRAY HOLDER
14	1	03-0256	RAMP WELDMENT
15	2	03-0302	SPREAD HOOK WELDMENT
16	2	03-0304	ROLLER WELD
17	2	03-0305	ADJUSTMENT POST WELDMENT
18	2	03-0308	HOOK POST WELDMENT
19	1	03-0309	TOOL TRAY WELDMENT
20	4	11-0023	NYLON ROLLER
21	2	020-024	CAP
22	8	028-010	1/4-20 x 3/4 HHC SCREW
23	14	028-012	5/16-18 x 3/4 HHC SCREW
24	2	028-021	3/8-16 X 1 HHC SCREW
25	1	028-025	1/2NC X 1-1/2 HHC SCREW
26	2	028-027	1/4 NC X 1/2 SOC SET SCREW
27	8	028-046	3/8-16 X 1-1/4 HEX CAP SCREW
28	1	028-047	1/2NC X 1-3/4 HHCS SCREW
29	14	028-133	3/8 NC X 3/4 HHC SCREW
30	1	028-207	NYLON TIP SET SCREW
31	4	028-210	1/4-20 UNC X 5/8 HHC SCREW
32	6	039-007	1" MACHINERY BUSHING
33	6	044-048	RETAINING RING
34	1	50-0027	3/8 X 1 SHOULDER SCREW
35	2	055-058	1/2-13NC BI-WAY LOCK NUT
36	14	055-103	3/8-16 SERR HEX FLG NUT
37	1	055-145	5/16-18 NYLON HEX LOCK NUT
38	10	055-154	/8-16 NYLON HEX LOCK NUT
39	4	061-091	1/4 X 7/8 SPRING PIN
40	7	096-004	1/4 NPT HSH PLUG FITTING
41	6	096-013	BRASS 1/4 NPT HEX NIPPLE
42	4	096-038	1/4-90° ST ELBOW
43	4	096-249	1/4 NPT TEE
44	6	096-342	1/4 TUBE ELBOW FITTING
45	2	54-0034	CLEVIS - (1/2 x 3) PIN
46	2	11-0075	ADJUSTER KNOB
47	1	73-0301	LOWER ROLLER ROD
48	1	73-0592	RETRACTOR BAR
49	2	73-0607	ANCHOR
50	2	73-1000	LOCK PIN

ITEM	QTY	PART NO.	DESCRIPTION
51	2	73-0743	RAMP BRACKET
52	2	73-0744	MANIFOLD
53	2	74-0076	CYLINDER SHAFT SLEEVE
54	4	107-020	PILLOW BLK BEARING
55	20	108-008	1/4 INT TOOTH WASHER
56	10	108-015	3/8 SAE FLAT WASHER
57	4	108-057	3/8 INT TOOTH LOCK WASHER
58	14	108-067	5/16 INT TOOTH WASHER
59	1	110-011	TENSION SPRING
60	2	110-065	CPRSN SPRING
61	1	900-187	4-1/2" CYLINDER ASSEMBLY
62	2	950-553	SHORT LINK

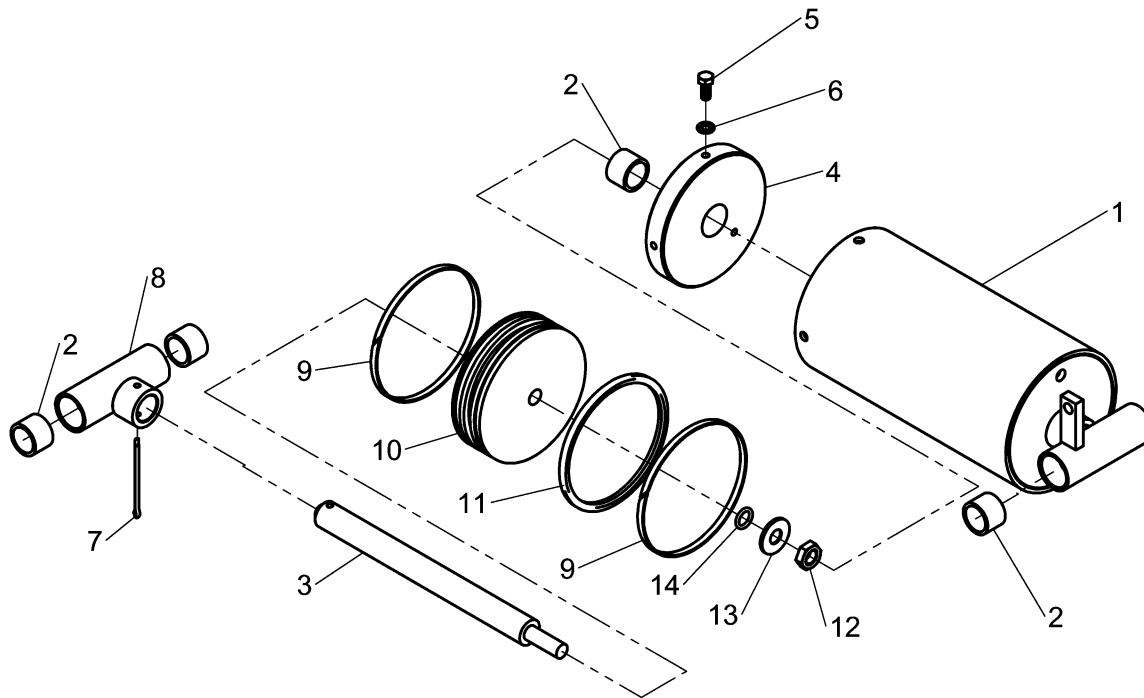

**LIFT CYLINDER ASSEMBLY**

ITEM	QTY	PART NO	DESCRIPTION
1	1	03-0240	LIFT CYL WELD.
2	5	039-041	SLEEVE BEARING
3	1	73-0746	LIFT PISTON ROD
4	1	01-0181	END COVER W/ BUSHING
5	4	028-012	5/16-18 x 3/4 HHC SCREW
6	4	108-067	5/16 WASHER
7	1	061-166	COTTER PIN
8	1	01-0074	ROD END WITH BEARING
9	2	11-0082	STRIP NYLON
10	1	73-0745	LIFT PISTON
11	1	61-0029	QUAD RING SEAL
12	1	055-111	9/16-18 LOCK NUT
13	1	52-0036	MODIFIED WASHER
14	1	041-049	#207 O-RING

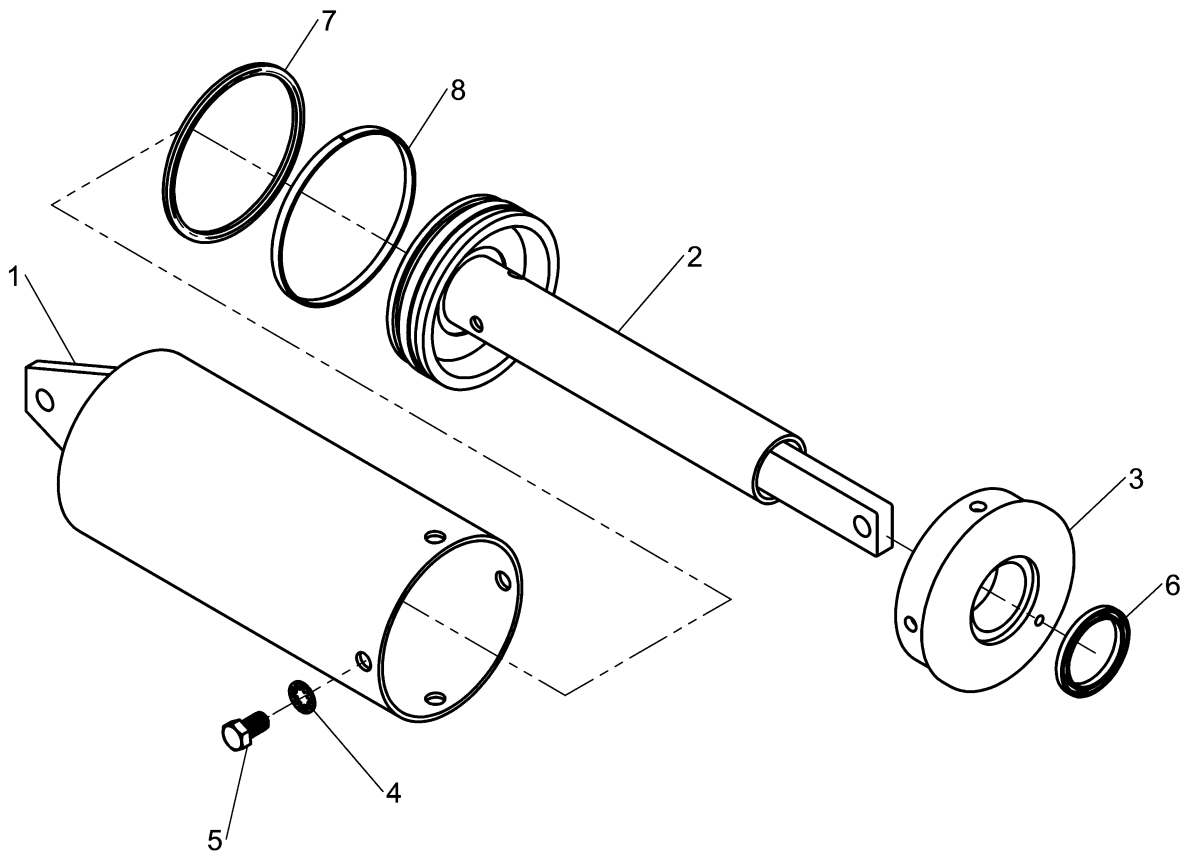

### SPREAD CYLINDER ASSEMBLY

ITEM	QTY	PART NO	DESCRIPTION
1	1	950-194	CYLINDER WELDMENT
2	1	950-195	PISTON & ROD ASS'Y
3	1	098-327	COVER PLATE
4	4	108-038	7/16 WASHER
5	4	028-005	7/16-14 x 3/4 HHC SCREW
6	1	041-202	ROD SEAL
7	1	61-0028	QUAD RING SEAL
8	1	11-0065	NYLON WEAR STRIP

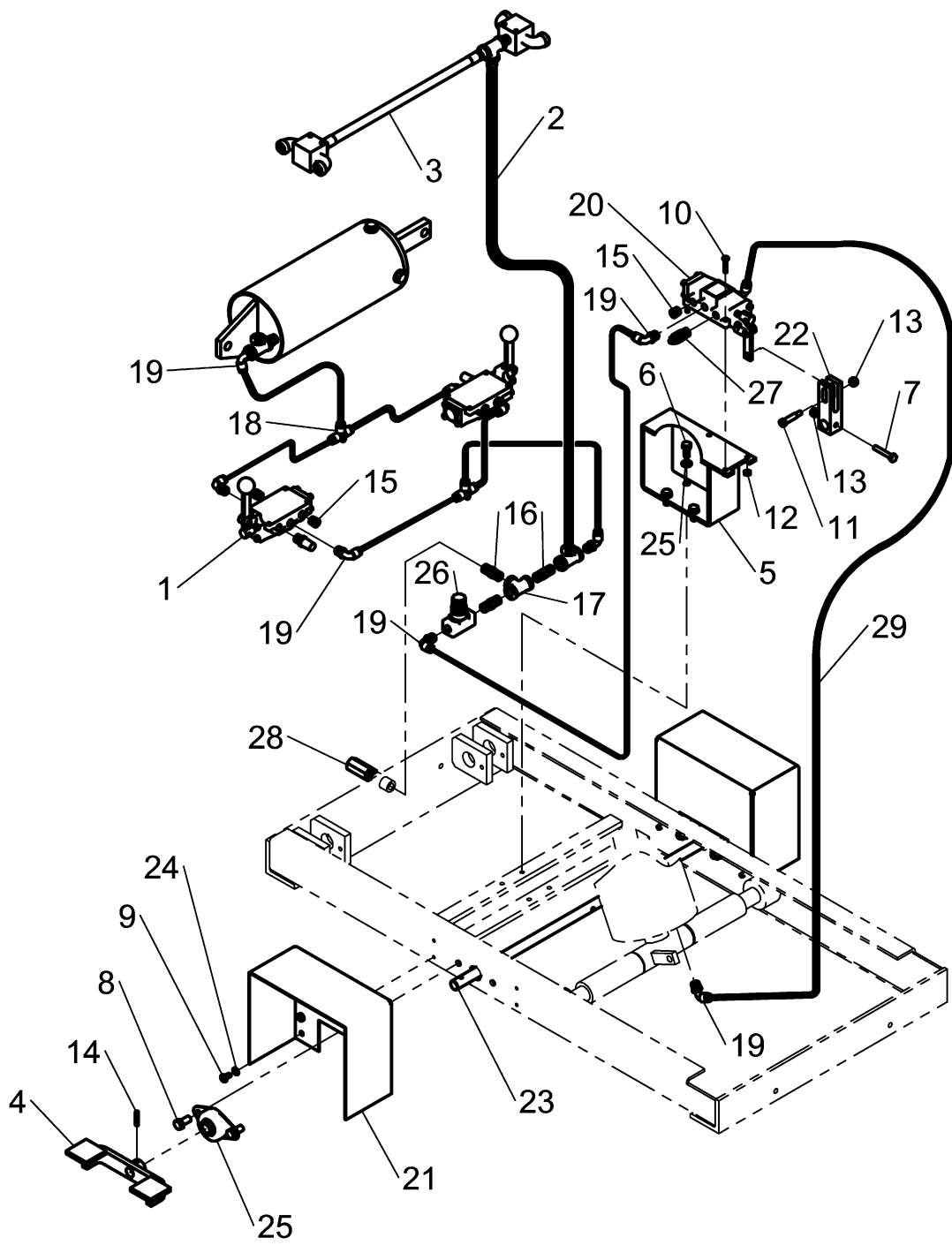

**PNEUMATICS ASSEMBLY**



ITEM	QTY	PART NO	DESCRIPTION
1	2	01-0199	VALVE SUB-ASS'Y
2	1	01-0200	LONG HOSE ASS'Y
3	1	01-0201	SHORT HOSE ASS'Y
4	2	03-0306	PEDAL WELDMENT
5	1	03-0307	VALVE MOUNT
6	14	028-012	5/16-18 x 3/4 HHC SCREW
7	1	028-078	CAPSCREW, 1/4 NC X 1-1/2
8	8	028-133	SCREW, 3/8 NC X 3/4 HHC
9	8	028-148	1/4 NC X 1/2 TAPPING SCREW
10	4	028-305	#10-24 X 2 PAN HD MC SCREW
11	1	028-353	5/16 X 1 SHOULDER SCREW
12	4	055-057	#10-24 HEX NUT
13	2	055-160	NYLON HEX LOCK NUT
14	2	061-178	3/16 X 1 SPRING PIN
15	7	096-004	1/4 NPT HSH PLUG FITTING
16	6	096-013	1/4 NPT HEX NIPPLE
17	4	096-249	1/4 NPT TEE
18	2	096-339	UNION TEE (1/4 TUBE)
19	6	096-342	1/4 TUBE ELBOW
20	1	60-0047	4-WAY VALVE
21	2	72-0086	FOOT GUARD
22	1	73-0733	VALVE CLEVIS
23	1	73-0734	LEVER ROD
24	12	108-008	1/4 INT TOOTH WASHER
25	14	108-067	5/16 INT TOOTH WASHER
26	1	190-249	1/4 NPT FLOW CONTROL
27	1	885-036	FLOW CONTROL MUFFLER
28	1	932-001	IN-LINE FILTER
29		D20-007	1/4 OD TUBE

## **NOTES:**

## **NOTES:**

## COMMERCIAL WARRANTY

This product is warranted by BRANICK INDUSTRIES, INC. to the original user-owner against defective materials or workmanship for a period of one year from the date of shipment. During the warranty period, at the discretion of Branick management, if the product is found to be defective, it will be repaired or replaced without charge. For service, contact Branick (800-437-4394) to obtain an RMA. Any product shipped to Branick must have an RMA and proof of original shipment date. The repaired or replacement product will be returned with transportation charges prepaid by Branick.

This warranty does not cover defects in the product caused by ordinary wear and tear, abuse, misuse, overloading, accident (including shipping damage), improper maintenance, alteration, or any other cause not the result of defective materials or workmanship.

REPAIR OR REPLACEMENT IS THE EXCLUSIVE REMEDY FOR DEFECTIVE PRODUCT UNDER THIS WARRANTY. THIS WARRANTY IS EXPRESSLY IN LIEU OF ALL OTHER WARRANTIES, INCLUDING ANY IMPLIED WARRANTY OF MERCHANT ABILITY OR ANY IMPLIED WARRANTY OF FITNESS FOR A PARTICULAR PURPOSE OF THIS PRODUCT. BRANICK INDUSTRIES, INC. SHALL NOT BE LIABLE FOR ANY CONSEQUENTIAL OR INCIDENTAL DAMAGES.

BRANICK INDUSTRIES, INC. reserves the right to make changes in the design or construction of our products without obligation to incorporate such changes in products already sold and without notice.

Service parts and regular repair service are available from authorized distributors of Branick products, or from:

BRANICK INDUSTRIES, INC.  
4245 Main Ave.  
 Fargo, North Dakota 58103  
Toll Free: 800-437-4394



[www.branick.com](http://www.branick.com)